

THE PROJECT

Among the improvement projects identified by DOBER LIDSKY MATHEY'S (DLM) 2005 campus plan study for Saint Xavier University was the need for updated and expanded facilities for the Graham School of Management's undergraduate and graduate programs. Several alternatives were studied for solving GSM's needs — combinations of new and renovated space and wholly new construction. A facility program was developed to guide the University's fund-raising efforts for a new building, to be constructed on a highly visible site. Detailed space descriptions were recorded to help the University's future design team capture the essential characteristics of new space that the GSM administration and faculty have envisioned as embodiments of their programs and curricula.

CHALLENGE

The School's expanded programs had grown beyond the capacity of an adapted neighborhood elementary school building. GSM administration and faculty needed help in defining and describing the essential characteristics and spatial relationships for a new facility to support evolving pedagogic trends and technological requirements.

SOLUTION

DLM worked with GSM's leadership and faculty through an interactive, 10-month process to develop a detailed program document describing over 125 characteristics for each space planned for the new building. All user groups were interviewed, including faculty, staff, and representative students. The final documentation resulted from a series of iterative drafts, each carefully reviewed with School representatives and University administrators.

RESULTS

The final facility program document described 113 functional spaces totalling 38,515 net assignable square feet. Critical adjacencies and vital spatial requirements were included in the report. Early project budget targets were established by the program's projections for the spaces required, evidence of the University's deliberative stewardship and careful management of resources.

*Project completed under previous name: Dober, Lidsky, Craig and Associates, Inc.



CAMPUS PLAN SITE LOCATION

Facility Program 2006

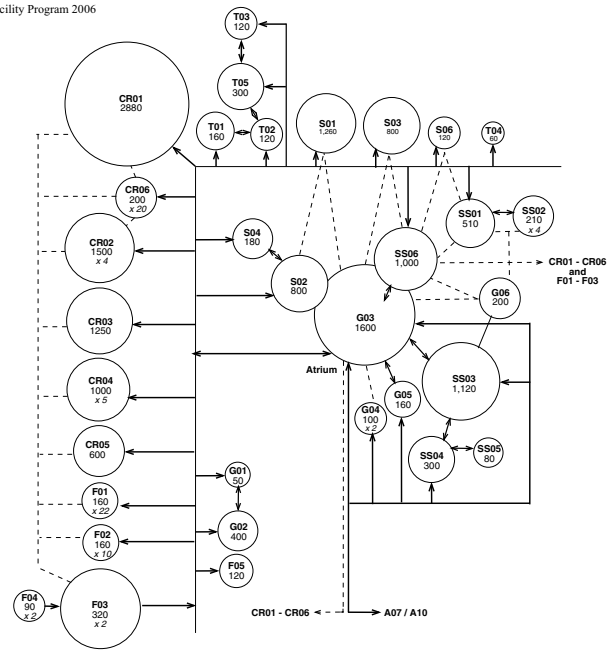

ADJACENCY DIAGRAM

REFERENCE

Paul Matthews
Assistant Vice President,
Facilities Management
773 298 3000 x 3548
pmatthews@sxu.edu

Dr. John Eber
Dean, Graham School of
Management
773 298 3601
eber@sxu.edu

PRINCIPAL IN-CHARGE

Richard P. Dober, AICP
Senior Consultant

George G. Mathey, AICP
Study Coordinator



DOBER LIDSKY MATHEY
CREATING CAMPUS SOLUTIONS